

**OPERATION, SPARE PARTS  
AND SERVICE MANUAL**

**PLATE COMPACTOR  
MODEL PP33**



**FAIRPORT**

**CONSTRUCTION EQUIPMENT LIMITED**

Blagden Street  
Sheffield  
S2 5QS  
ENGLAND

Tel: +44 (0) 114 276 7921  
Fax: +44 (0) 114 272 0965  
Email: [sales@fairport.uk.com](mailto:sales@fairport.uk.com)  
Web: [www.fairport.uk.com](http://www.fairport.uk.com)

<b>CONTENTS</b>		<b>PAGE</b>
1.	SAFETY .....	2
1.1	SAFETY PICTOGRAMS USED ON FAIRPORT EQUIPMENT .....	2
1.2	SAFETY DECAL POSITIONS.....	3
2.	TECHNICAL DATA .....	4
3.	USING THE MACHINE FOR THE FIRST TIME.....	4
4.	ROUTINE MAINTENANCE .....	4
5.	STARTING THE ENGINE .....	5
6.	OPERATOR INSTRUCTIONS .....	5
7.	VEE BELT ADJUSTMENT .....	5
8.	WARRANTY CONDITIONS AND CLAIMS PROCEDURE .....	5
	CONDITIONS .....	6
	CLAIMS PROCEDURE .....	6
9.	REPAIRS AND ESTIMATES .....	7
10.	ENVIRONMENT.....	7
11.	PARTS LIST .....	8
	DRIVE SYSTEM .....	8
	HANDLE AND ENGINE BEDPLATE.....	9
	BASEPLATE AND VIBRATOR.....	10
	POLYPAD MAT KIT .....	14
	WATER SPRINKLER KIT.....	15
12	DECLARATION OF CONFORMITY.....	17

## 1. SAFETY

DO NOT operate this machine unless all guards are in position and secure.

DO NOT smoke when refuelling.

DO NOT refuel with engine running.

Wipe up spilt fuel.

DO NOT overfill.

Dispose of fuel contaminated wipes safely

DO NOT run engine in enclosed areas without adequate ventilation.

DO NOT run engine in an area that has a hazardous or explosive atmosphere.

Disconnect H.T. lead from spark plug on petrol engines before carrying out any maintenance.

Turn off fuel when not using machine.

Wear protective footwear, ear defenders and gloves.

Comply with site safety regulations.

Check condition and tightness of anti-vibration mounts between engine plate and base plate before lifting.

### 1.1 SAFETY PICTOGRAMS USED ON FAIRPORT EQUIPMENT



Wear ear protectors



Wear eye protection



Wear gloves



Wear protective footwear



Wear a mask



Read the operators manual for this equipment



This surface may be hot

## 1.2 SAFETY DECAL POSITIONS

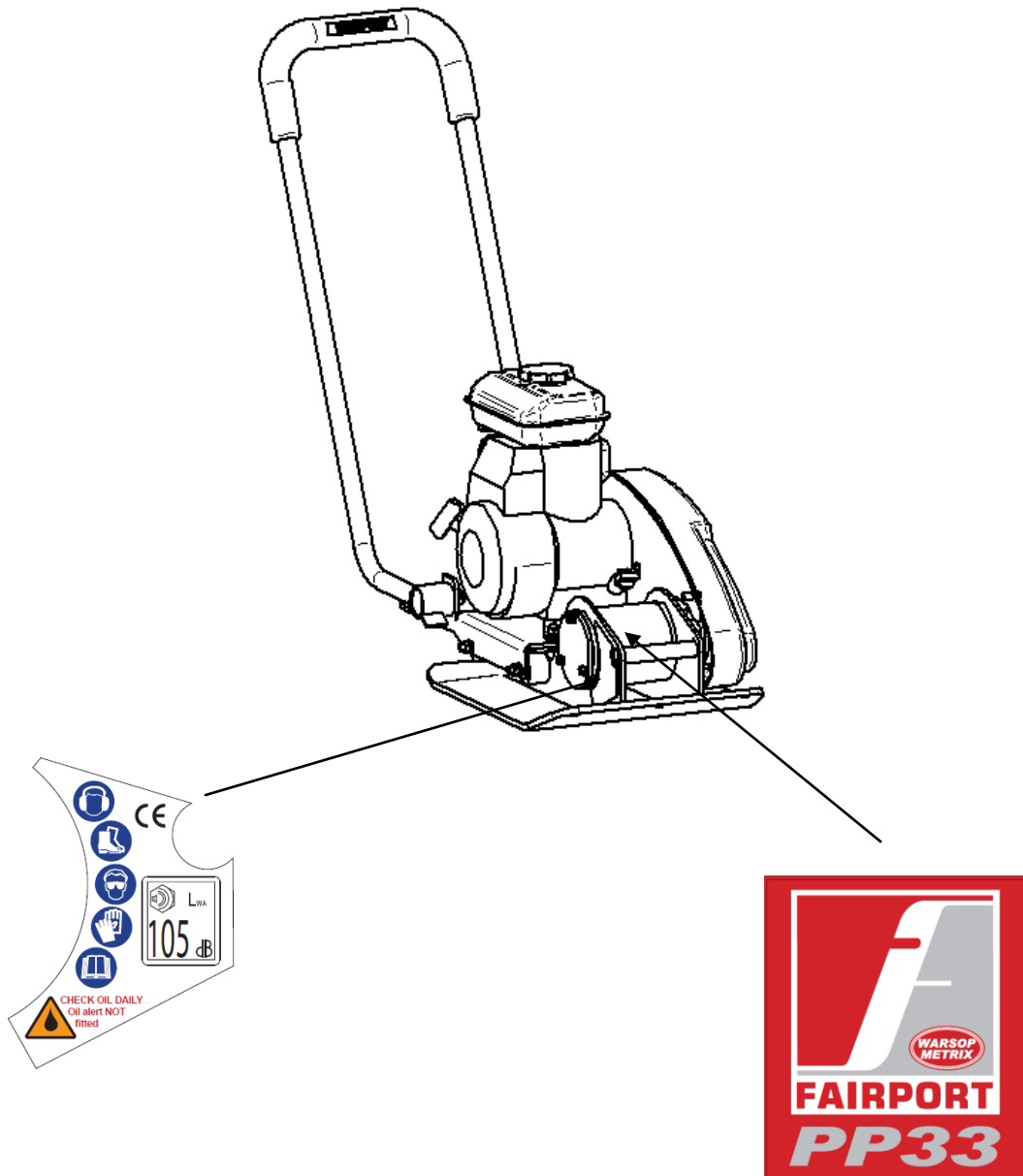

## 2. TECHNICAL DATA

### ENGINE

MODEL	ENGINE MANUFACTURER	ENGINE MODEL	POWER (HP/kW)
PP33	Honda	GX100	3.0/2.2

### DIMENSIONS

MODEL	HEIGHT- H (mm)	LENGTH - L (mm)	WIDTH - W (mm)	CONTACT AREA (sq. m)	WEIGHT (kg)
PP33	788	1010	330	0.099	45

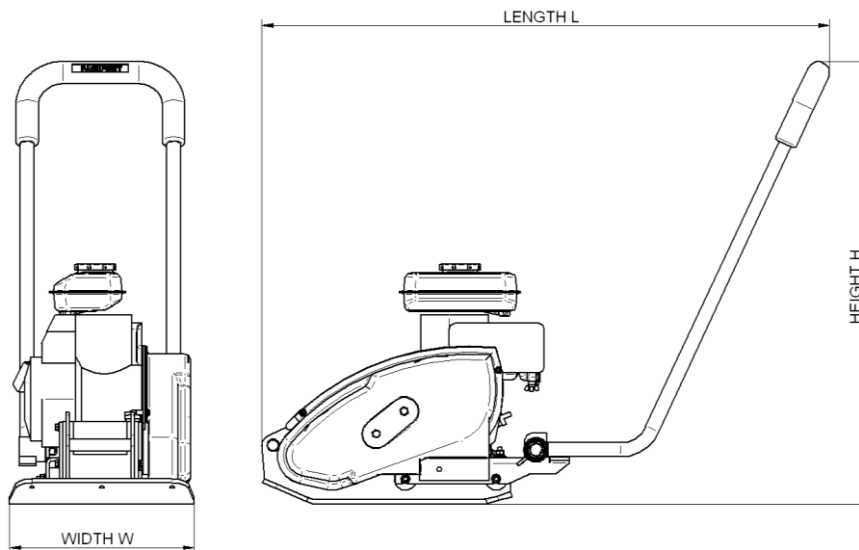

### PERFORMANCE

MODEL	CENTRIFUGAL FORCE (kN)	COMPACTION RATIO (kg/m <sup>2</sup> )
PP33	10	452

### NOISE AND VIBRATION EMISSIONS

The Guaranteed Sound Power level (LWA) tested according to ISO3744 and the Machinery Directive is 105dB(A).

\*The 3-Axis Hand Arm Vibration Value tested in accordance with BS 500-4 on uncompacted granular sub base materials is 12.5 m/s<sup>2</sup>.

### 3. USING THE MACHINE FOR THE FIRST TIME

When the machine is delivered from Fairport it will have **no oil in the engine**. Please refer to the Engine Manufacturers Manual issued with the machine for instructions on filling the engine with the correct type and quantity of oil.

### 4. ROUTINE MAINTENANCE

(See Also The Engine Manufacturers Manual issued with the machine)

Daily: Check engine oil level twice daily.  
Check tightness of all fastenings after first days use, thereafter check monthly.  
Check belt tension after the first days use, thereafter check monthly.  
Clean air filter daily if working in dusty conditions.  
Clean base plate thoroughly if compacting black-top or lean concrete.

Weekly: Clean air filter (see “daily”).

Monthly: Check tightness of fastenings.  
Check condition and tightness of anti-vibration mounts. Poor condition of vibration mountings can lead to a deterioration of the product vibration levels.  
Check belt tension.

### 5. STARTING THE ENGINE

Check oil level.  
Turn fuel tap on.  
Put speed control lever to tick-over.  
If engine is cold, close the choke (petrol engines only).  
Turn engine switch to ON(1) position.  
Pull the starter rope toggle lightly until resistance is felt, then pull briskly using quick short pull. Do not pull rope to its full extent or allow toggle to snap back against engine. Return gently to avoid damage.

When the engine is warm, open choke.  
Position engine speed control lever to give required engine speed (usually full speed).  
Commence vibration – the compactor is self – travelling.  
To stop the engine, position the engine speed control to slow and turn the engine switch to off(0).  
Turn the fuel valve off.

### 6. OPERATOR INSTRUCTIONS

Read section (1) - Safety.  
NOTE: Drive between engine and vibrator is through a centrifugal clutch. Vibration will commence as engine speed is increased.  
Position the engine speed control lever to give required speed (usually full speed).  
Commence compaction. The compactor is self-travelling. Its speed of travel and the number of passes required to achieve optimum compaction depends on the type and condition of material being compacted and the layer depth.  
Uniformly graded granular material compacts far more efficiently than wet cohesive

material.

When Compacting block paving always use a rubber attachment mat, contact your agent for details.

When compacting blacktop always use a water spray, contact your agent for details.

Do not run the machine on solid surfaces, as this is likely to cause damage.

## **7. VEE BELT ADJUSTMENT**

It is important to note that belt tension in this application is much less than is generally accepted as normal. Too high a belt tension may lead to engine damage, excessive vibration in the handle, short belt life and short vibrator shaft bearing life due to excessive transmission of vibration through the belt. Correct adjustment is achieved by moving the engine back to take the slack out of the belt. With light finger pressure on top of the belt and at the centre of the span, a deflection of between 5mm and 10mm is expected.

## **8. WARRANTY CONDITIONS AND CLAIMS PROCEDURE**

All products supplied by Fairport Construction Equipment Ltd (hereafter referred to as FCE) are warranted to be free of defects due to faulty materials or workmanship for a period of 12 months from the date of original despatch from FCE or 3 months for all spare parts used in repairs carried out by FCE or an authorised dealer or repairer.

If the goods have been purchased through a stockist the above warranty periods also apply from receipt of the goods by the user of the equipment up to a total of a further 6 months from date of despatch from FCE whichever is earlier.

Filter elements, gauges and oils are specifically excluded from this warranty.

FCE shall at their option repair or replace, during normal working hours, goods accepted as faulty free of charge to the user.

For proprietary items such as engines, the original manufacturer's warranty and conditions shall apply.

### CONDITIONS

The goods shall be returned at the purchaser's expense to FCE or to a destination FCE may reasonably direct. Carriage costs will be refunded if warranty is accepted.

Warranty claims will not be considered where there is evidence that failure has been caused by carelessness, improper use, negligence, inadequate servicing, incorrect engine speeds, fair wear and tear or non-compliance with instructions issued by the manufacturer.

To the extent permitted by law, the liability of FCE under this section is confined only to providing a remedy for defective goods and does not extend to any consequential loss, loss of profit, injury or damage suffered.

Warranty will not be accepted on dismantled goods unless dismantling was carried out with the written permission of FCE.

No claim shall be considered if other than genuine parts supplied by FCE have been used.

Products are only covered by this warranty in the country to where they were supplied by FCE.

Warranty on products applies only to the original user of the equipment.

This warranty shall not apply if the serial number or other identifying numbers or marks applied by FCE have been removed, defaced or are otherwise illegible.

### CLAIMS PROCEDURE

Check that the goods are still under warranty before returning them to FCE (see above for warranty periods).

Return the goods to FCE with an order number for the work to proceed. If warranty is accepted no charge will be made. If warranty is not accepted a quotation will be given for the repair and the conditions under the section headed REPAIRS AND ESTIMATES will apply.

In the customer's interest, goods must be accompanied by documentation detailing the nature of the fault or its symptoms. Phrases such as 'Faulty' are unacceptable and will result in delays and possible charges to defray costs incurred in identifying the fault.

In the case of hydraulic breakers and power packs, both the breaker and the pack should be returned.

## **9. REPAIRS AND ESTIMATES**

When returning a machine, or an assembly for repair, always include an Advice Note quoting model and serial number of the machine.

An official order must also be forwarded to FCE giving detailed instructions. No repair work can be carried out unless covered by an official order.

An estimate will be submitted before proceeding with any repair. To partly cover the cost in dismantling, cleaning and inspection, a small charge will be made; this however will be waived upon receipt of your official instructions to proceed with the repair.

In the event of the estimate not being accepted, a further charge will be made to defray the rebuilding of the machine.

Estimates must be treated as approximate only as it may be found necessary to use additional parts on further examination.

## **10. ENVIRONMENT**

This machine contains materials that can be recycled. We recommend that when the machine is disposed off it is done safely and in a way that protects the environment.

Part Description	Materials
Engine	Aluminium and steel
Baseplate	Steel
Engine Frame	Steel
Engine Bedplate	Steel
Belt Cover	High Density Polyethylene
Handle	Steel and Polyurethane
Ant vibration Mounts	Steel and rubber
Block Paving Kit (if fitted)	Steel and Polyurethane
Water Bottle Kit (if fitted)	Steel and Medium Density Polyethylene



## 11. PARTS LIST – DRIVE SYSTEM

<u>Parts List</u>	<u>Part Code</u>	<u>Description</u>	<u>Qty Required</u>
1	W81925	Honda GX100	1
2	W14681	Engine Spacer	1
3	W14810	Belt Guard Back Plate	1
4	W466/5/12	5/16 UNF x 3/4" Csk Setscrew	4
5	W14812	Clutch Spacer	1
6	W87218	Vee Belt	1
7	W87061	Clutch	1
8	W525/4/16	Retaining Washer	1
9	W432/6	M6 Spring Washer	1
10	P80167	1/4 UNF x 1" Setscrew (FPC320)	1
11	W14702	Belt Guard	1
12	W437/8/25	M8 x 25 Setscrew	2
13	W432/8	M8 Spring Lock Washer	2
14	W418/8	M8 Washer	2
15	P83028	M6 x 16 Button Head Screw	2
16	W439/6	M6 Shakeproof Washer	2
17	W14680	Engine Fixing Plate	1
18	W437/8/30	M8 x 30 Hex Setscrew	4
19	W88914	AV Buffer	1
20	W14733	Buffer Bracket	1
21	W440/10	M10 Nut	1
22	W418/10	M10 Washer	1
23	W432/10	M10 Spring Lock Washer	1

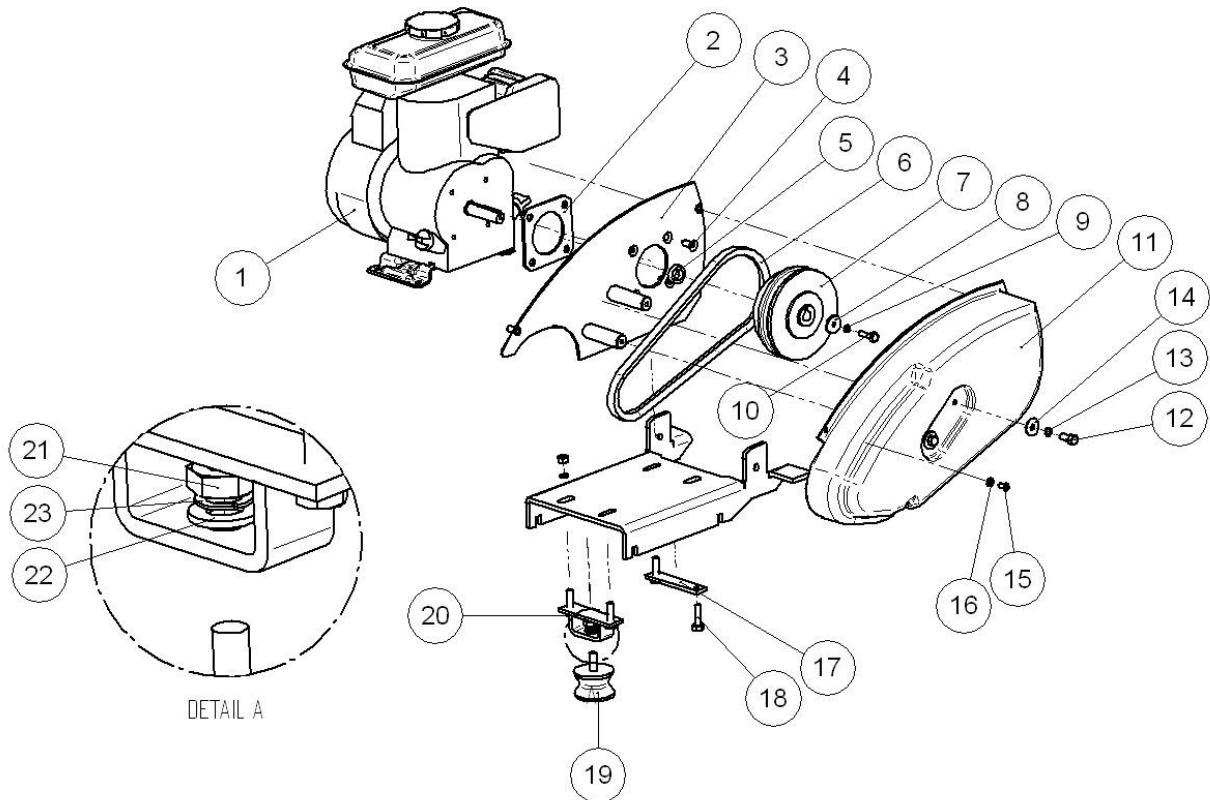

## PARTS LIST – HANDLE AND ENGINE PLATE

<u>Parts List</u>	<u>Part Code</u>	<u>Part Description</u>	<u>Qty Required</u>
1	W14611	Handle	1
2	W88912	Handle Bush	2
3	W14683	Handle Pivot Bolt	2
4	W480/12	M12 Nyloc Nut	2
5	W88918	AV Mount – Front Right/Rear Left	2
6	W437/8/16	M8 x 16 Setscrew	4
7	W432/8	M8 Spring Lock Washer	4
8	W418/8	M8 Washer	4
9	W14612	Engine Bed Plate	1

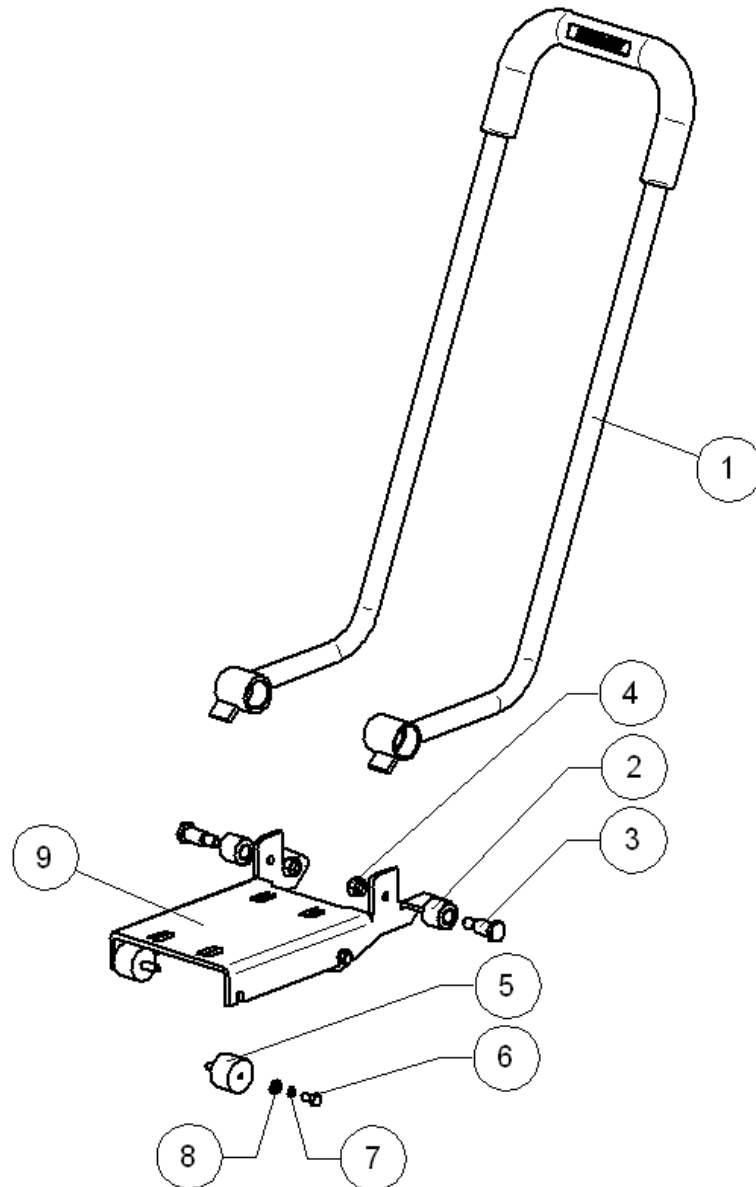

## PARTS LIST – BASEPLATE AND VIBRATOR ASSEMBLY

<u>Parts List</u>	<u>Part Code</u>	<u>Description</u>	<u>Qty Required</u>
1	W14609	Base	1
2	W14610	Eccentric Weight	1
3	W81041	Bearing	2
4	W81153	Oil Seal	1
5	W14601	End Cap (Pulley Side)	1
6	W14613	Pulley	1
7	W435/12/40	M12 x 40 Bolt	1
8	W526/12/40	M12 Large Washer	1
9	W432/12	M12 Spring Lock Washer	1
10	W432/6	M6 Spring Lock Washer	6
11	W437/6/16	M6 x 16 Setscrew	6
12	W88917	AV Mount – Rear Right/Front Left	2
13	W418/8	M8 Washer	4
14	W432/8	M8 Spring Lock Washer	4
15	W440/8	M8 Nut	4
16	W14600	End Cap (Non-Pulley Side)	1
17	W437/8/16	M8 X 16 Setscrew	4

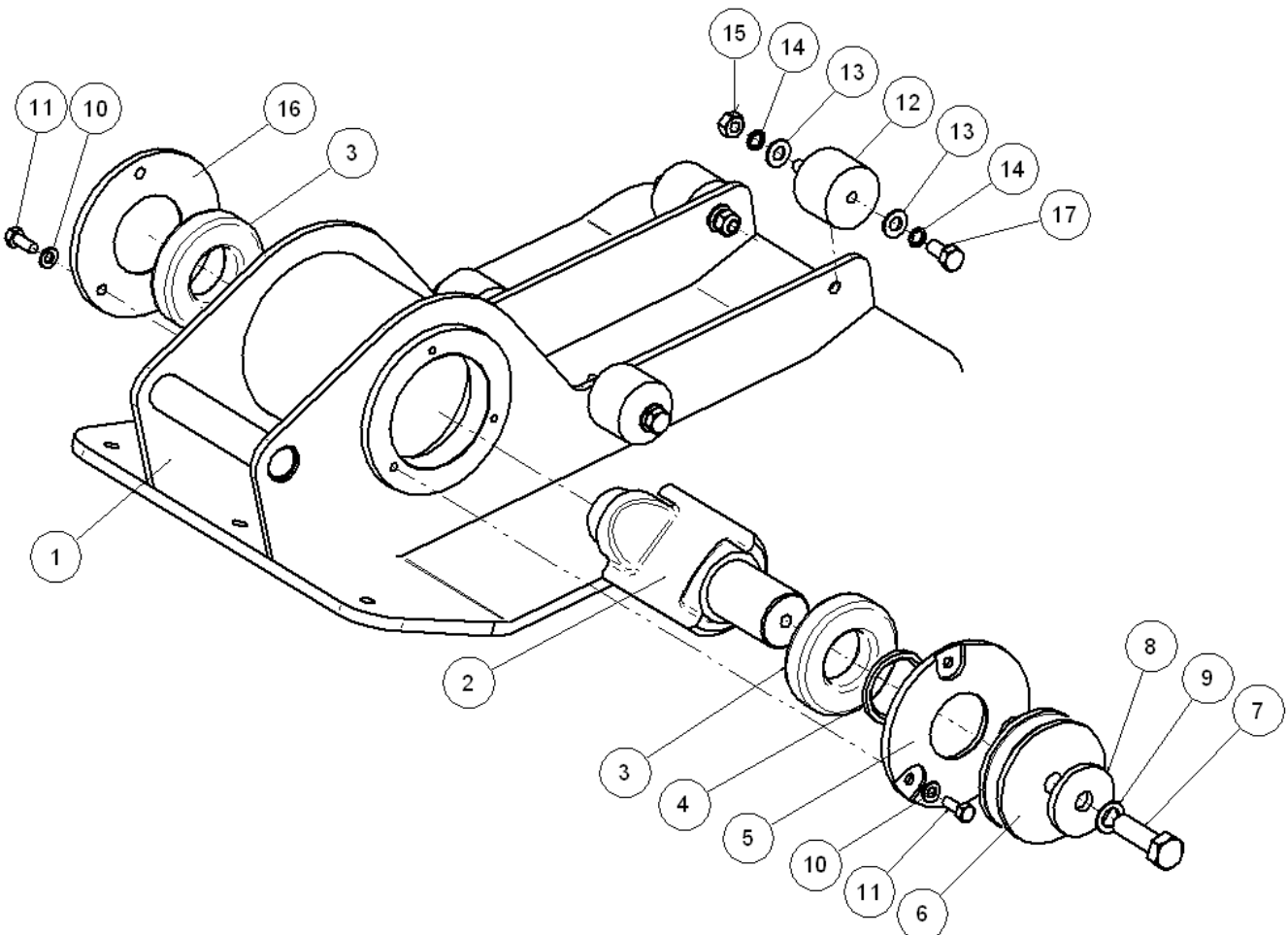

## BLOCK COMPACTING MAT KIT

<u>Part Code</u>	<u>Description</u>	<u>Qty Required</u>
93011	Block compacting mat kit comprising:	
W14574	Clamp strip	1
W14573	Rubber mat	1
W435/8/35	M8 x 35 hex. Hd. bolt	3
W480/8	M8 Nyloc nut	3
W418/8	M8 star washer	6

## WATER SPRINKLER KIT

<u>Parts List</u>	<u>Part Code</u>	<u>Description</u>	<u>Qty Required</u>
	93043	Water sprinkler kit comprising:	
1	W480/6	M6 Nyloc Nut	4
2	W55042	Spacer	1
3	W420/6	M6 Washer	4
4	W55041	Tank Support	1
5	W51673	Spray Tube	1
6	W 418/8	M8 Washer	3
7	W435/8/25	M8 x 25 Bolt	3
8	W480/8	M8 Nyloc Nut	3
9	W55043	TANK c/w Cap	1
10	W55044	Strap	2
11	W87864	Ball Valve	1
12	W87856	¼" BSP Plug	1

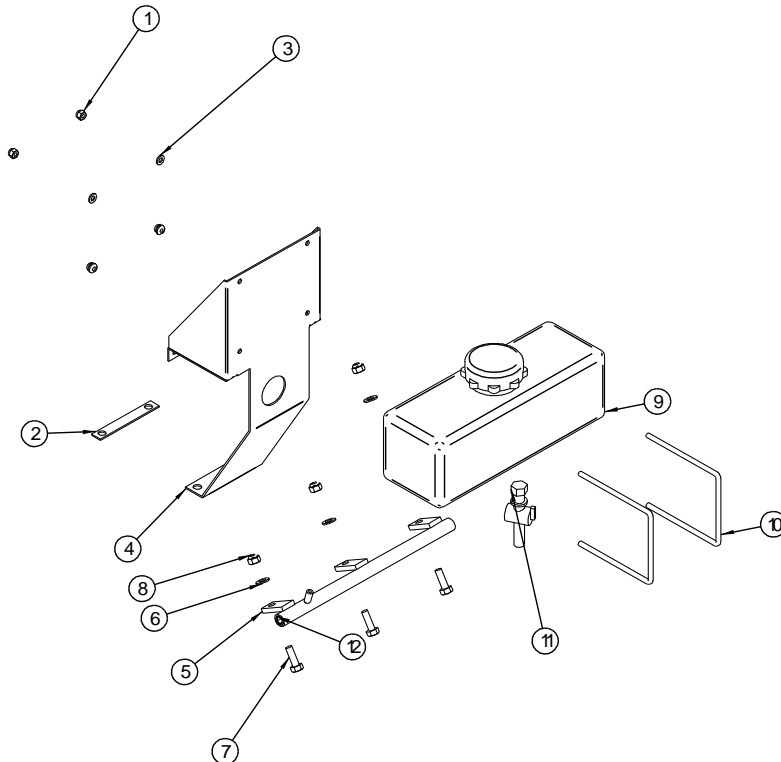

## 12. EC DECLARATION OF CONFORMITY

**WE, FAIRPORT CONSTRUCTION EQUIPMENT LTD, BLAGDEN ST, SHEFFIELD,  
SOUTH YORKSHIRE, S2 5QS**

DECLARES THAT THE PRODUCT:

**PP33; FITTED WITH A HONDA GX100 ENGINE**

ENGINE POWER; 3.0HP/2.2kW at 3600RPM

SERIAL No.  
.....

CONFORMS TO THE FOLLOWING DIRECTIVE:

**89/336/EEC, 89/392/EEC, 91/368/EEC, 2000/14/EC**

NOTIFIED BODY; **AV Technology Ltd, AVTECH House, Arkle Avenue, Stanley  
Green Trading Estate, Handforth, Cheshire. SK9 3RW.**

USES THE FOLLOWING STANDARDS:

**BS EN 292-1, BS EN 292-2, BS EN 294, BS EN 500-4**

CONFORMS TO THE FOLLOWING STATUTORY INSTRUMENTS

**THE SUPPLY OF MACHINERY (SAFETY) REGULATIONS 1992 &  
AMMENDMENTS**

COMPLIES WITH THE RELEVANT ESSENTIAL HEALTH & SAFETY  
REQUIREMENTS OF THE MACHINERY DIRECTIVE

DECLARATION

**I certify that on completion of manufacture of the machine detailed above that a  
full conformity has been completed and relevant Health and Safety  
Requirements complied with.**

NAME: **IAN MORRIS**

STATUS WITHIN COMPANY: **TECHNICAL MANAGER**

SIGNATURE:

